

## Powertec RF Directional Coupler, 5 dB, 698 to 3800 MHz, 4.3-10 Female, -155 dBc

### Model Number

PCM-DC5-6938.432

### GTIN-13

9337692001918

### Component Type

Directional Coupler

### Usage

IBC / DAS

### RF Category

Cellular



Directional Couplers are used to develop complex RF transmission systems where unbalanced signal power levels are required, or to counteract and balance an unbalanced system.

Powertec's range of directional couplers have been designed for use in 4G-5G transmission and in-building coverage systems, supporting a wide frequency range from 700 to 3800 MHz, extremely low intermodulation with a -155 dBc PIM rating, and using 5G-compatible 4.3-10 connectors. The model provides exceptional inter-port isolation between coupled and output ports.

With an IP65 ingress protection rating the power divider can be used indoors or outdoors. A sturdy removable stainless steel mounting bracket is included.

- 4.8 dB (5 dB) coupling value
- Meets Powertec OTAR & MCF IBC design standards
- Stainless Steel mounting bracket
- IP65 ingress protection rating for harsh environments

# Component Technical Data

## PHYSICAL CHARACTERISTICS

Construction Material	Aluminium	RF Connections	3
Finish	Powder Coat	Environmental Rating	IP65
Dimensions	167 x 67 x 42 mm	Operating Temperature	-25 °C to 85 °C
Weight	540 g	Mounting	Screw / Bolt

## RF PERFORMANCE

Input Ports	1	Output Ports	2
Frequency Range	698 to 3800 MHz	Input Impedance	50 Ω
Inter-Port Isolation	> 23 dB	VSWR	< 1.25:1
Max. Input Power	> 300 W	PIM, 3 <sup>rd</sup> Order	< -155 dBc

PORT NUMBER	FUNCTION	INSERTION LOSS	CONNECTOR
Port #1	Input	0.35 dB	4.3-10 Female
Port #2	Coupled	4.80 dB	4.3-10 Female
Port #3	Output	1.80 dB	4.3-10 Female

# CAD Drawing

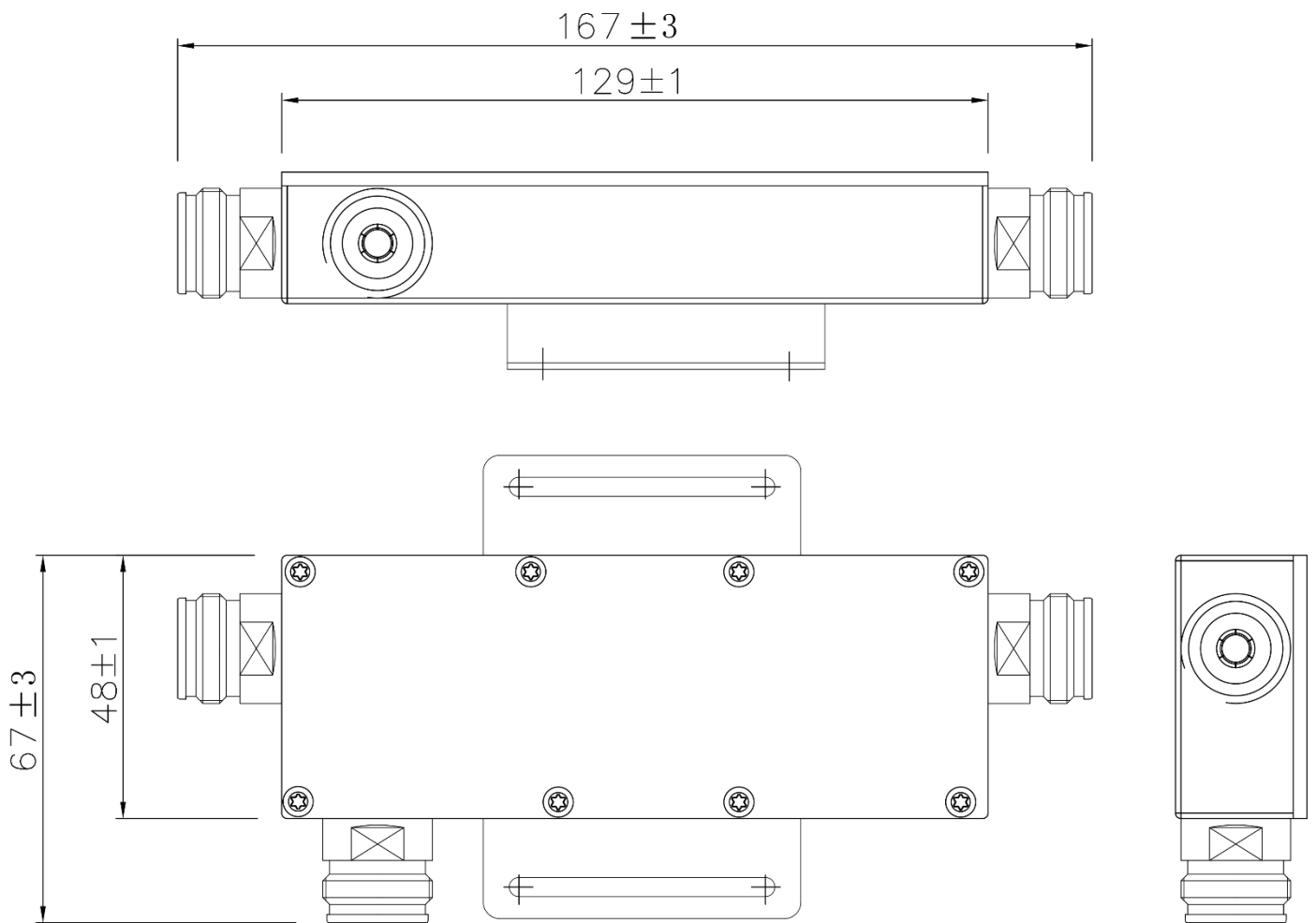



Document Generated on 27/05/2022 4:57 PM

Disclaimer: Although care has been taken to ensure the accuracy, completeness and reliability of the information provided, Powertec assumes no responsibility therefore. The user of the information agrees that the information is subject to change without notice. Powertec assumes no responsibility for the consequences of use of such information, nor for any infringement of third party intellectual property rights which may result from its use. IN NO EVENT SHALL POWERTEC BE LIABLE FOR ANY DIRECT, INDIRECT, SPECIAL, OR INCIDENTAL DAMAGE RESULTING FROM, ARISING OUT OF OR IN CONNECTION WITH THE USE OF THE INFORMATION.



**OBSEQUIA**  
SAFETY CERTIFIED  
AS/NZS 4801:2001



**OBSEQUIA**  
QUALITY CERTIFIED  
ISO 9001:2015



**OBSEQUIA**  
ENVIRONMENT CERTIFIED  
ISO 14001:2015

